

4

ZAG

Die-Cast Aluminium Enclosures

SX Range
1

BFG Range
2

BPGA Range
3

ZAG Range
4

High Voltage
5

Fire Rated
6

ZP Range
7

Others
8

Technical
9

Further details on this range of enclosures can be found at;

www.ab-tech.co.uk/zag.htm



Die-cast Aluminium Enclosures

The ZAG range of enclosures comprises of 19 different sizes of enclosures and is precision die cast in AL-Si 12 grade (LM24) aluminium alloy. This is considered to be the most suitable grade of aluminium for maximum corrosion resistance especially in salt laden atmospheres.

Additional optional protection methods such as anochrome, anodising and epoxy polyester painting coupled with the fitment of captive 316 grade stainless steel lid retaining screws further enhance the anti-corrosion properties of the enclosure.



The wall thickness is sufficient to allow tapped entry holes to be machined into the walls or the base of the enclosure.

Due to the enclosure's labyrinth seal system, similar to that of the BPG range of enclosures, whereby the seal is protected from external forces, the ZAG enclosure has excellent ingress protection qualities this means that the enclosure has been tested to and passed IP65/66/67.

The mounting holes, although contained within the profile of the enclosure, sit outside the seal and all the external fasteners and fixings are manufactured from 316 grade stainless steel to ensure the enclosures reliability. External stainless steel mounting feet are offered as an option.

The ZAG range has many features which lend itself to a whole host of applications including junction boxes, both industrial and hazardous area, and especially OEM applications, where the excellent machining qualities of aluminium come to the fore.

The ZAG range can be drilled and tapped with various thread forms and it readily accepts most paint finishes and colours.



The ZAG range is particularly suitable for the engraving of instructions and decals and this method provides excellent durability. Silk screen printing is also available.

All of this can be achieved even in relatively small batches which makes the ZAG range ideal for the small to medium size manufacturers who can achieve a custom enclosure economically.

Earthing of the enclosure can be accomplished by various means. Internal / external stainless steel earth studs which in turn can be connected to the terminal mounting rail or component plate and various rail mounted earth terminals or proprietary earth bars can be fitted inside the enclosure. Due to the fact that aluminium is an excellent conductor, earthing for cable glands is provided through contact with the enclosure wall with no further earthing required.



When fitted with a standard neoprene gasket the enclosure is suitable for ambient temperatures - 40°C to + 80°C (-40°F to +176°F).

Alternatively, when fitted with an optional silicon gasket the temperature range can be increased to - 70°C to + 130°C (-94°F to +266°F).



The ZAG enclosures are suitable for use in hazardous areas and can be supplied with a number of certificates;

ATEX EEx'e' to BS EN 50019 (zone 1 & 2) EEx 'nA' to BS EN 50021 (zone 2) and NEMA 4x (CSA, UL & FM class 1, division 2).

The ZAG range can also be supplied fitted with any component approved terminal to apparatus level or can be supplied empty as component approved for the clients own certification requirements.

Further information on enclosure certification can be found in Section 9 of this catalogue.



ZAG Range Features

- Wide Operating Temperature (- 70°C to +130°C) (-94°F to +266°F)
- Ingress Protection up to IP67
- Painted and Unpainted versions
- Impact Resistant > 7 Nm
- Corrosion Resistant
- Can be drilled and tapped to accommodate most thread forms (NPT for example)
- Certification for use in Zone 1 and 2
- UL, CSA, ATEX, FM, InMetro and GOST Approvals
- Ideal for Petrochemical and Marine applications

SX Range

1

BPG Range

2

BPGA Range

3

ZAG Range

4

High Voltage

5

Fire Rated

6

ZP Range

7

Others

8

Technical

9

Accessories and Options

The following table is a list of the available accessories suitable for a particular size of ZAG enclosure. Care should be taken when ordering accessories for use with enclosures intended for hazardous areas to ensure that compliance with certification is retained.

Part Number	Width (mm)	Length (mm)	Depth (mm)	UP - Unpainted	EX - Ex Certified (see note 1)	AL - Anodised	ES - Earth Stud	AS - Allen Head Fixing Screws	TP - Tamper Proof Screws	EH - External Hinges	MP - Component Mounting Plate	MF - External Mounting Feet	EB - Internal Earthing Bar	SG - Silicone Gasket (see note 2)	MR - DIN Standard Mounting Rail	RF - RFI Protection (see note 3)
ZAG1	50	45	30	✓	✗	✓	✗	✓	✓	✗	✗	✗	✗	✓	✗	✓
ZAG2	58	64	34	✓	✓	✗	✗	✓	✓	✗	✓	✗	✗	✓	✗	✓
ZAG3	98	64	34	✓	✓	✓	✓	✓	✓	✗	✓	✗	✗	✓	✗	✓
ZAG4	150	64	34	✓	✓	✓	✓	✓	✓	✗	✓	✓	✗	✓	✗	✓
ZAG5	75	80	57	✓	✓	✓	✓	✓	✓	✓	✓	✓	✗	✓	✓	✓
ZAG6	125	80	57	✓	✓	✗	✓	✓	✓	✓	✓	✓	✗	✓	✓	✓
ZAG7	175	80	57	✓	✓	✓	✓	✓	✓	✓	✓	✓	✗	✓	✓	✓
ZAG8	250	80	56	✓	✓	✓	✓	✓	✓	✓	✓	✓	✗	✓	✓	✓
ZAG9	122	120	80	✓	✓	✓	✓	✓	✓	✓	✓	✓	✓	✓	✓	✓
ZAG9/9	122	120	90	✓	✓	✓	✓	✓	✓	✓	✓	✓	✓	✓	✓	✓
ZAG10	220	120	80	✓	✓	✓	✓	✓	✓	✓	✓	✓	✓	✓	✓	✓
ZAG10/9	220	120	90	✓	✓	✓	✓	✓	✓	✓	✓	✓	✓	✓	✓	✓
ZAG11	160	160	90	✓	✓	✓	✓	✓	✓	✓	✓	✓	✓	✓	✓	✓
ZAG12	260	160	90	✓	✓	✓	✓	✓	✓	✓	✓	✓	✓	✓	✓	✓
ZAG13	360	160	90	✓	✓	✓	✓	✓	✓	✓	✓	✓	✓	✓	✓	✓
ZAG14	560	160	90	✓	✓	✓	✓	✓	✓	✓	✓	✓	✓	✓	✓	✓
ZAG15	202	230	110	✓	✓	✓	✓	✓	✓	✓	✓	✓	✓	✓	✓	✓
ZAG16	330	230	110	✓	✓	✓	✓	✓	✓	✓	✓	✓	✓	✓	✓	✓
ZAG21	120	360	80	✓	✓	✓	✓	✓	✓	✓	✓	✓	✓	✓	✓	✓

Ordering Example;

ZAG10 UP AS SG

(ZAG 10 unpainted, Allen Head Fixing Screws and Silicone Lid Gasket)

1. EEx'e' certification may be component or apparatus certified - please specify your requirements.
2. Silicone gasket increases temperature rating (-70°C to +130°C) (-94°F to +266°F).
3. Radio Frequency Interference (RFI) gasket may reduce IP rating. Enclosure may also be internally coated with RFI material.



Unpainted (raw) finish

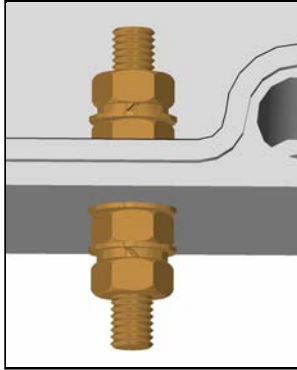

Earth Stud
(either brass or stainless steel)

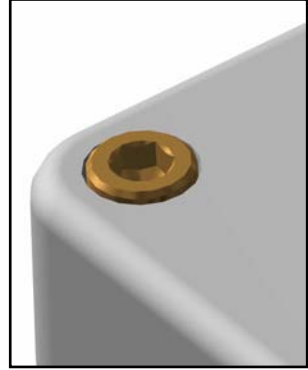

Allen Head fixing screws
(grade 316)

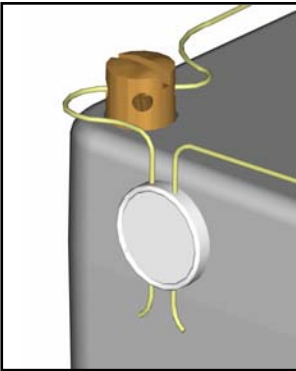

Tamper-proof screws

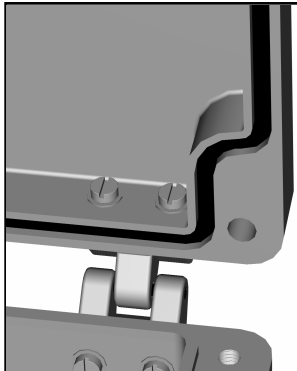

External hinges

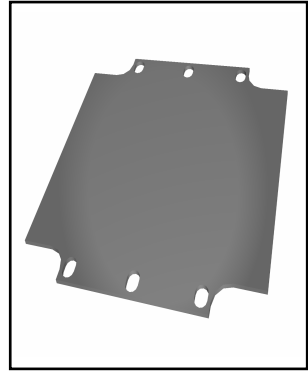

Component mounting plate
(tufnol as standard, steel an option)

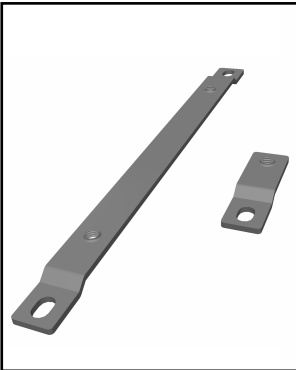

External mounting feet
(stainless steel 316)

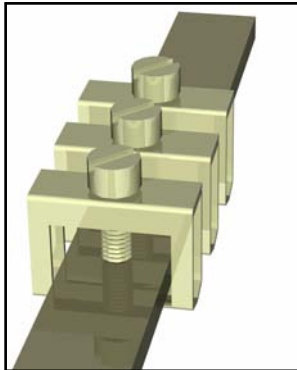

Internal Earthing bar
(can be fitted with clamps)



DIN standard mounting rail
(TS15, TS32 or TS35)

SX Range	1
BPG Range	2
BPGA Range	3
ZAG Range	4
High Voltage	5
Fire Rated	6
ZP Range	7
Others	8
Technical	9

We can also supply cable glands, stopping plugs, breather drains and continuity plates. Please contact for further details.

ZAG 1 Drawing

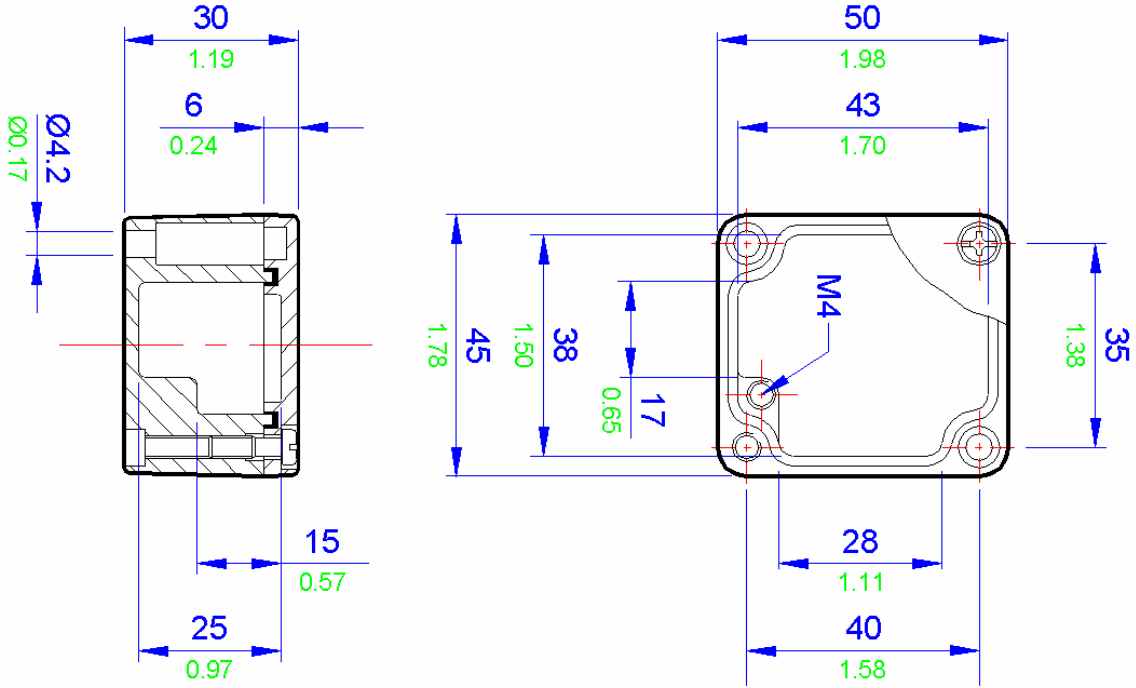

All blue dimensions in mm, all green dimensions in decimal inches (drawing not to scale)

ZAG 1 Specifications

Width	50mm
Length	45mm
Depth	30mm
Material	Precision Cast AlSi12 (LM24) aluminium alloy - unpainted
	Precision Cast AlSi12 (LM24) aluminium alloy – painted epoxy polyester RAL7001 grey
Weight	75g
IP Rating	65
Temperature	-40° to 80° C (-40°F to +176°F) (standard neoprene gasket)
	-70° to 130° C (-94°F to +266°F) (silicone gasket)
Certification	N/A
Power Rating	N/A

Terminal Populations

Maximum Number of Rows		1	
Weidmuller		Wago	
BK4 (4 way)	0	280-992	0
BK6 (6 way)	0	280-999	0
BK12 (12 way)	0	281-691	0
MK6/3	0	281-992	0
MK6/4	0	281-993	0
MK6/6	0	282-691	0
SAK2.5	0	284-691	0
SAK4	0	283-691	0
SAK6N	0	285-691	0
SAK10	0	280-998	0
SAK16	0	281-998	0
SAK35	0	264-120	6
Entrelec		264-220	3
MA2.5/5	0	264-132 (2)	0
M4/6	0	264-134 (4)	0
M6/8	0	262-132 (2)	0
M10/10	0	262-134 (4)	0
M16/12	0		
M35/16	0		

Cable Gland Entry Matrix

Entry Size	Side A-C	Side B-D
M16	0	0
M20	0	0
M25	0	0
M32	0	0
M40	0	0

Drilling Envelope Size

Side A-C	24 x 21mm
Side B-D	16 x 21mm

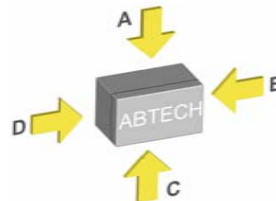

Example



ZAG 2 Drawing

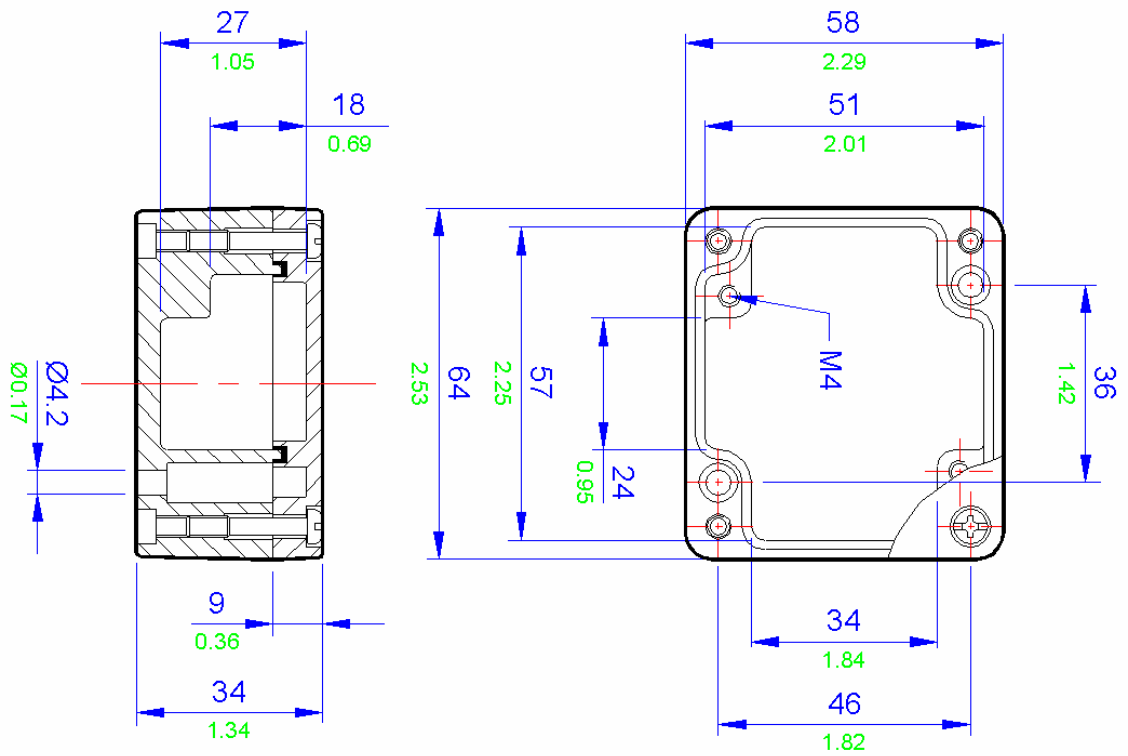

All blue dimensions in mm, all green dimensions in decimal inches (drawing not to scale)

ZAG 2 Specifications

Width	58mm
Length	64mm
Depth	34mm
Material	Precision Cast AlSi12 (LM24) aluminium alloy - unpainted
	Precision Cast AlSi12 (LM24) aluminium alloy – painted epoxy polyester RAL7001 grey
Weight	170g
IP Rating	65
Temperature	-40° to 80° C (-40°F to +176°F) (standard neoprene gasket)
	-70° to 130° C (-94°F to +266°F) (silicone gasket)
Certification	ATEX EEx'e' BS EN 50019 (Zone 1 & 2)
	ATEX EEx'nA' BS EN 50021 (Zone 2)
	NEMA 4X (CSA, UL & FM (class 1 division 2)
Power Rating	0.900W

Terminal Populations

Maximum Number of Rows		1	
Weidmuller		Wago	
BK4 (4 way)	1	280-992	0
BK6 (6 way)	0	280-999	0
BK12 (12 way)	0	281-691	0
MK6/ 3	1	281-992	0
MK6/4	0	281-993	0
MK6/6	0	282-691	0
SAK2.5	0	284-691	0
SAK4	0	283-691	0
SAK6N	0	285-691	0
SAK10	0	280-998	0
SAK16	0	281-998	0
SAK35	0	264-120	0
Entrelec		264-220	0
MA2.5/5	0	264-132 (2)	0
M4/6	0	264-134 (4)	0
M6/8	0	262-132 (2)	0
M10/10	0	262-134 (4)	0
M16/12	0		
M35/16	0		

Cable Gland Entry Matrix

Entry Size	Side A-C	Side B-D
M16	0	0
M20	0	0
M25	0	0
M32	0	0
M40	0	0

Drilling Envelope Size

Side A-C	21 x 20mm
Side B-D	29 x 20mm

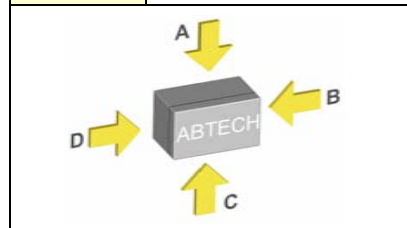

Example

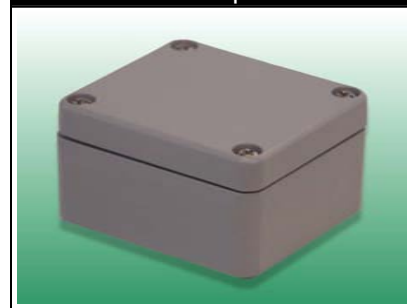

Technical

9

Others

8

ZP Range

7

Fire Rated

6

High Voltage

5

ZAG Range

4

BPGA Range

3

BPG Range

2

SX Range

1

ZAG 3 Drawing

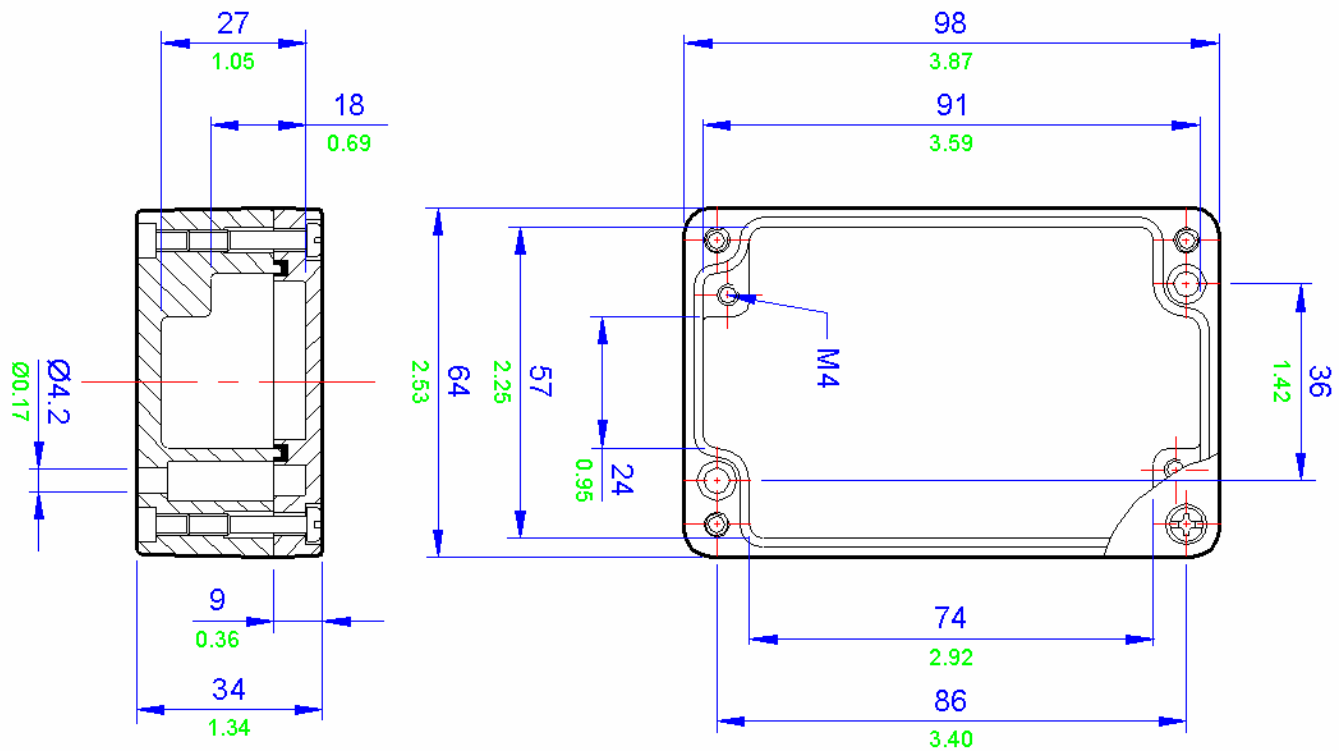

All blue dimensions in mm, all green dimensions in decimal inches (drawing not to scale)

ZAG 3 Specifications	
Width	98mm
Length	64mm
Depth	34mm
Material	Precision Cast AISi12 (LM24) aluminium alloy - unpainted
	Precision Cast AISi12 (LM24) aluminium alloy – painted epoxy polyester RAL7001 grey
Weight	220g
IP Rating	65
Temperature	-40° to 80° C (-40F to +176F) (standard neoprene gasket)
	-70° to 130° C (-94F to +266F) (silicone gasket)
Certification	ATEX EEx'e' BS EN 50019 (Zone 1 & 2)
	ATEX EEx'h'A' BS EN 50021 (Zone 2)
	NEMA 4X (CSA, UL & FM (class 1 division 2)
Power Rating	1.200w

Terminal Populations			
Maximum Number of Rows			1
Weidmuller		Wago	
BK4 (4 way)	1	280-992	0
BK6 (6 way)	1	280-999	0
BK12 (12 way)	0	281-691	0
MK6/3	1	281-992	0
MK6/4	1	281-993	0
MK6/6	1	282-691	0
SAK2.5	0	284-691	0
SAK4	0	283-691	0
SAK6N	0	285-691	0
SAK10	0	280-998	0
SAK16	0	281-998	0
SAK35	0	264-120	0
Entrelec		264-220	0
MA2.5/5	0	264-132 (2)	0
M4/6	0	264-134 (4)	0
M6/8	0	262-132 (2)	0
M10/10	0	262-134 (4)	0
M16/12	0		
M35/16	0		

Cable Gland Entry Matrix		
Entry Size	Side A-C	Side B-D
M16	0	0
M20	0	0
M25	0	0
M32	0	0
M40	0	0

Drilling Envelope Size	
Side A-C	68 x 21mm
Side B-D	19 x 21mm

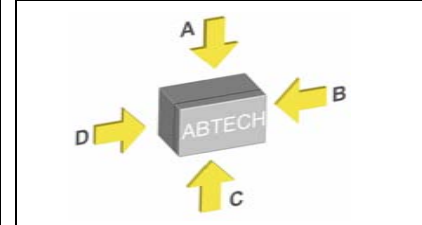

Example

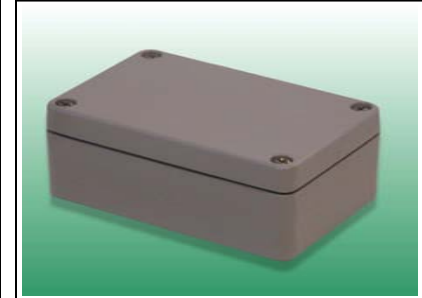

Technical	Others	ZP Range	Fire Rated	High Voltage	ZAG Range	BPGA Range	BPG Range	SX Range
9	8	7	6	5	4	3	2	1

ZAG 4 Drawing

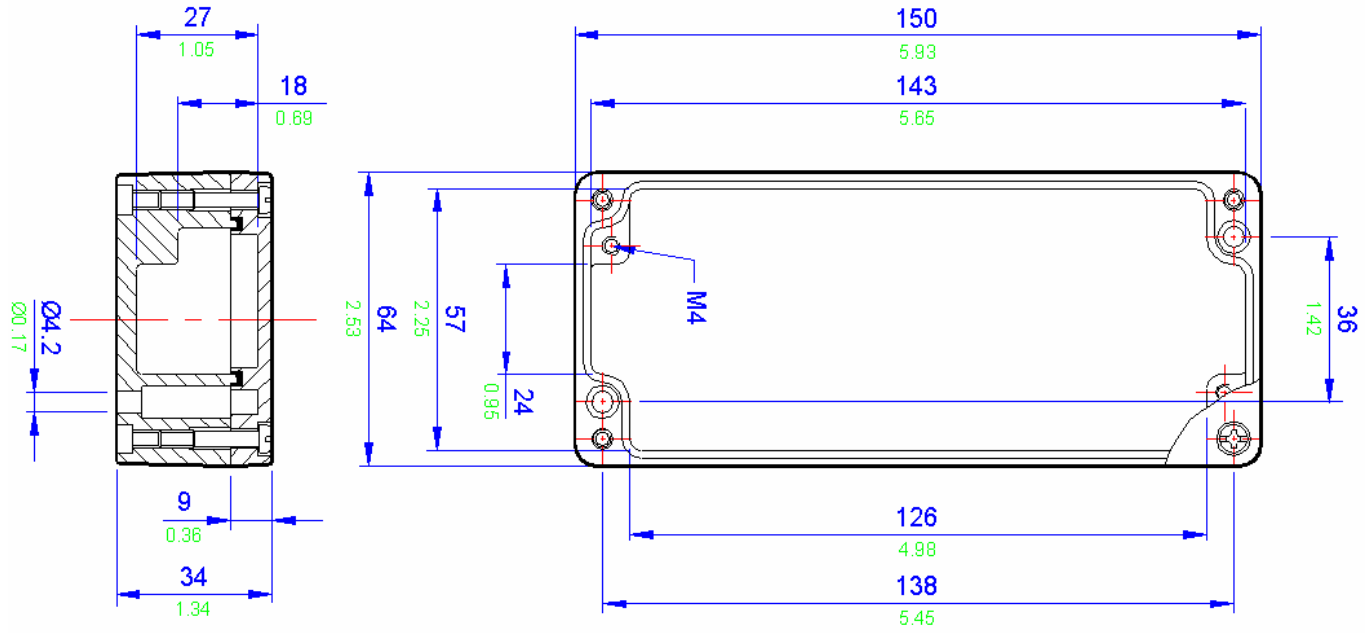

All blue dimensions in mm, all green dimensions in decimal inches (drawing not to scale)

ZAG 4 Specifications	
Width	150mm
Length	64mm
Depth	34mm
Material	Precision Cast AlSi12 (LM24) aluminium alloy - unpainted
	Precision Cast AlSi12 (LM24) aluminium alloy – painted epoxy polyester RAL7001 grey
Weight	330g
IP Rating	67
Temperature	-40° to 80° C (-40°F to +176°F) (standard neoprene gasket)
	-70° to 130° C (-94°F to +266°F) (silicone gasket)
Certification	ATEX EEx'e' BS EN 50019 (Zone 1 & 2)
	ATEX EEx'nA' BS EN 50021 (Zone 2)
	NEMA 4X (CSA, UL & FM (class 1 division 2)
Power Rating	1.700w

Terminal Populations			
Maximum Number of Rows			1
Weidmuller		Wago	
BK4 (4 way)	3	280-992	0
BK6 (6 way)	2	280-999	0
BK12 (12 way)	1	281-691	0
MK6/3	3	281-992	0
MK6/4	2	281-993	0
MK6/6	1	282-691	0
SAK2.5	0	284-691	0
SAK4	0	283-691	0
SAK6N	0	285-691	0
SAK10	0	280-998	0
SAK16	0	281-998	0
SAK35	0	264-120	0
Entrelec		264-220	0
MA2.5/5	0	264-132 (2)	0
M4/6	0	264-134 (4)	0
M6/8	0	262-132 (2)	0
M10/10	0	262-134 (4)	0
M16/12	0		
M35/16	0		

Cable Gland Entry Matrix		
Entry Size	Side A-C	Side B-D
M16	0	0
M20	0	0
M25	0	0
M32	0	0
M40	0	0

Drilling Envelope Size	
Side A-C	120 x 22mm
Side B-D	20 x 22mm

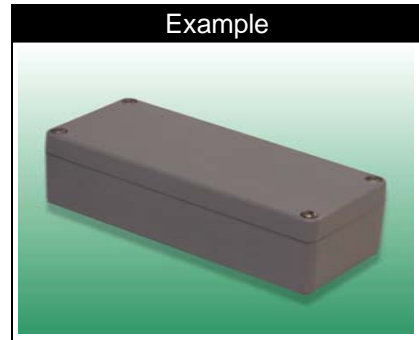
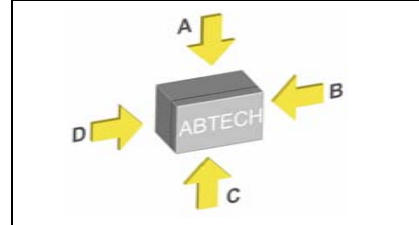

Technical 9	Others 8	ZP Range 7	Fire Rated 6	High Voltage 5	ZAG Range 4	BPGA Range 3	BPG Range 2	SX Range 1
----------------	-------------	---------------	-----------------	-------------------	----------------	-----------------	----------------	---------------

ZAG 5 Drawing

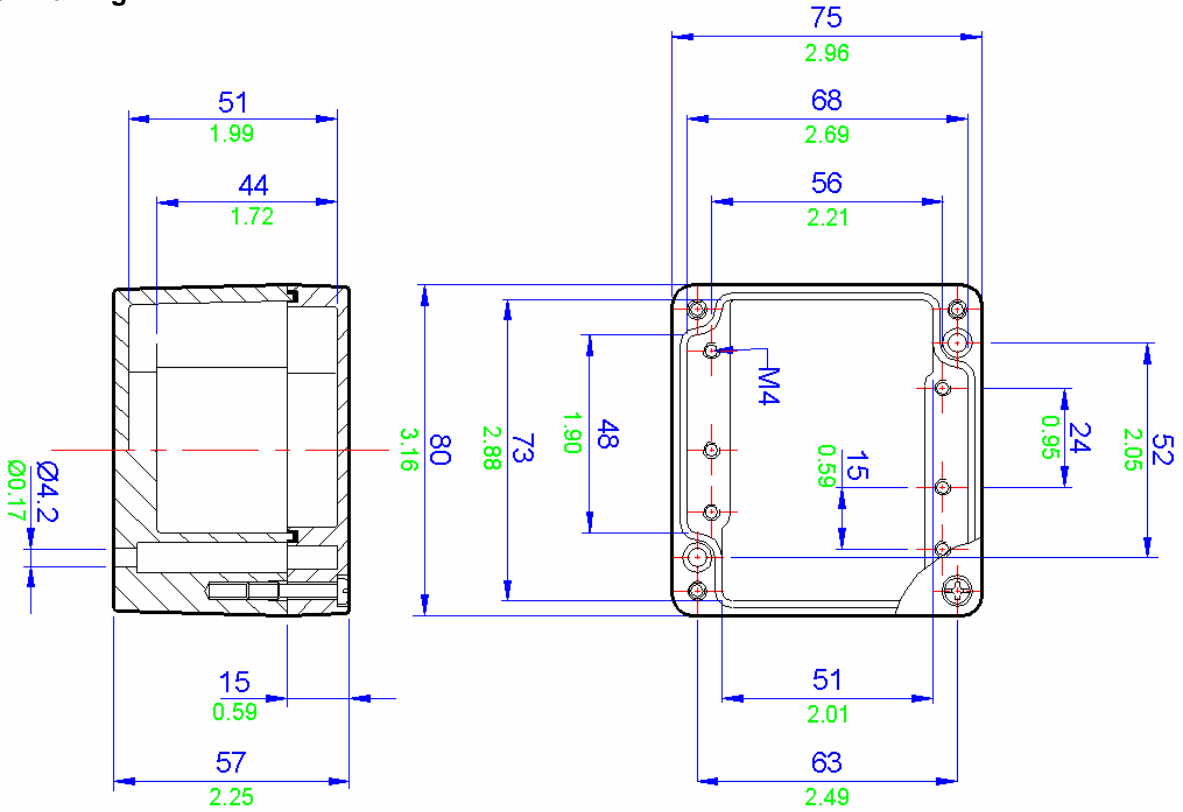

All blue dimensions in mm, all green dimensions in decimal inches (drawing not to scale)

ZAG 5 Specifications	
Width	75mm
Length	80mm
Depth	57mm
Material	Precision Cast AlSi12 (LM24) aluminium alloy - unpainted
	Precision Cast AlSi12 (LM24) aluminium alloy – painted epoxy polyester RAL7001 grey
Weight	290g
IP Rating	67
Temperature	-40° to 80° C (-40°F to +176°F) (standard neoprene gasket)
	-70° to 130° C (-94°F to +266°F) (silicone gasket)
Certification	ATEX EEx'e' BS EN 50019 (Zone 1 & 2)
	ATEX EEx'nA' BS EN 50021 (Zone 2)
	NEMA 4X (CSA, UL & FM (class 1 division 2)
Power Rating	1.500w

Terminal Populations			
Maximum Number of Rows			1
Weidmuller		Wago	
BK4 (4 way)	1	280-992	0
BK6 (6 way)	0	280-999	0
BK12 (12 way)	0	281-691	0
MK6/3	1	281-992	0
MK6/4	1	281-993	0
MK6/6	0	282-691	0
SAK2.5	0	284-691	0
SAK4	0	283-691	0
SAK6N	0	285-691	0
SAK10	0	280-998	0
SAK16	0	281-998	0
SAK35	0	264-120	6
Entelec		264-220	3
MA2.5/5	0	264-132 (2)	1
M4/6	0	264-134 (4)	0
M6/8	0	262-132 (2)	1
M10/10	0	262-134 (4)	0
M16/12	0		
M35/16	0		

Cable Gland Entry Matrix		
Entry Size	Side A-C	Side B-D
M16	1	0
M20	0	0
M25	0	0
M32	0	0
M40	0	0

Drilling Envelope Size	
Side A-C	41 x 37mm
Side B-D	39 x 31mm

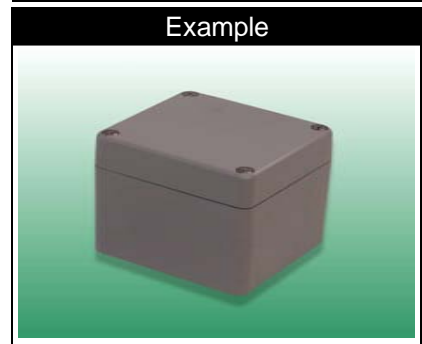
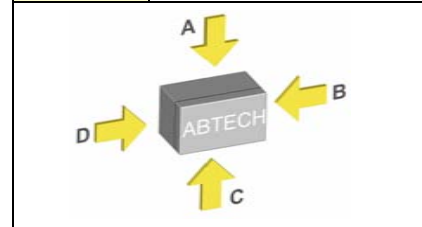

Technical 9	Others 8	ZP Range 7	Fire Rated 6	High Voltage 5	ZAG Range 4	BPGA Range 3	BPG Range 2	SX Range 1
----------------	-------------	---------------	-----------------	-------------------	----------------	-----------------	----------------	---------------

ZAG 6 Drawing

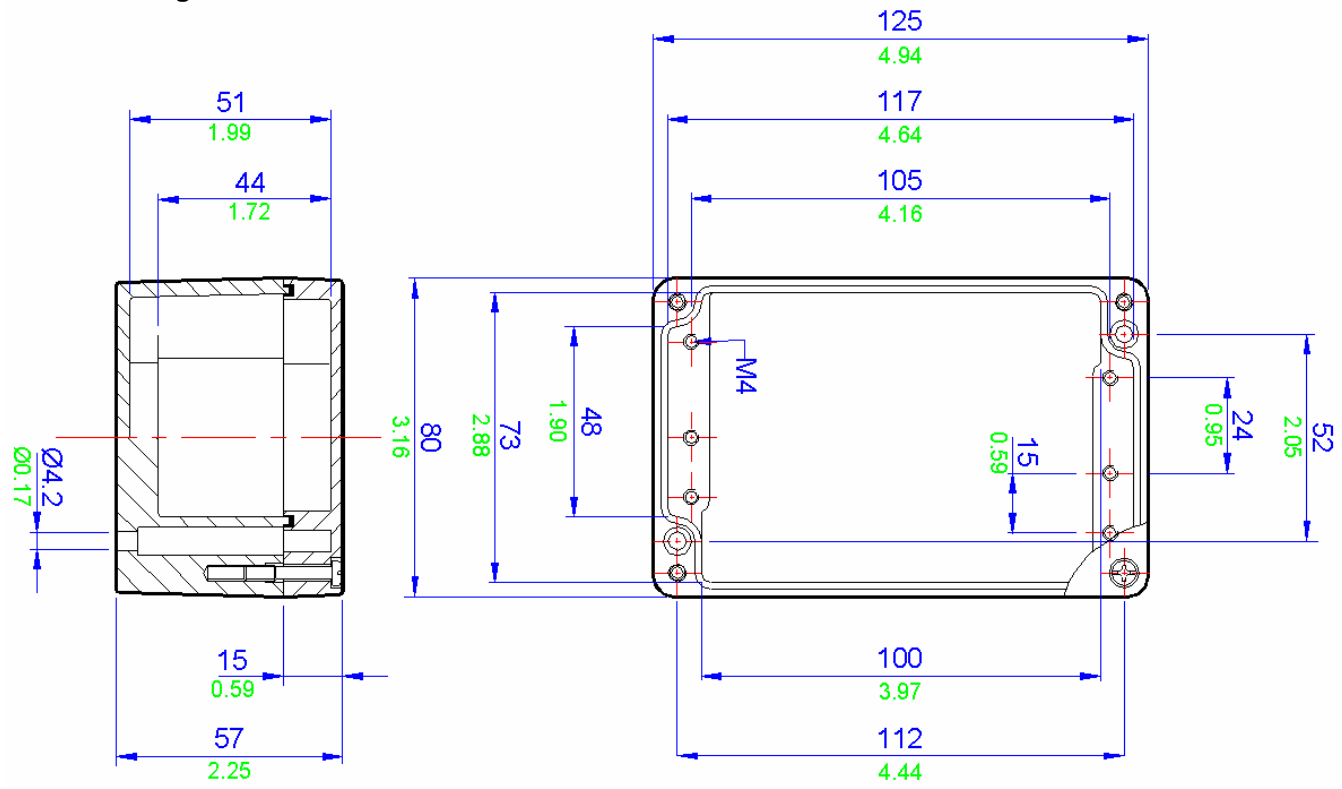

All blue dimensions in mm, all green dimensions in decimal inches (drawing not to scale)

ZAG 6 Specifications

Width	125mm
Length	80mm
Depth	57mm
Material	Precision Cast AlSi12 (LM24) aluminium alloy - unpainted
	Precision Cast AlSi12 (LM24) aluminium alloy – painted epoxy polyester RAL7001 grey
Weight	435g
IP Rating	67
Temperature	-40° to 80° C (-40°F to +176°F) (standard neoprene gasket)
	-70° to 130° C (-94°F to +266°F) (silicone gasket)
Certification	ATEX EEx'e' BS EN 50019 (Zone 1 & 2)
	ATEX EEx'nA' BS EN 50021 (Zone 2)
	NEMA 4X (CSA, UL & FM (class 1 division 2)
Power Rating	2.200w

Terminal Populations

Maximum Number of Rows		1	
Weidmuller		Wago	
BK4 (4 way)	2	280-992	0
BK6 (6 way)	1	280-999	0
BK12 (12 way)	1	281-691	0
MK6/3	2	281-992	0
MK6/4	1	281-993	0
MK6/6	1	282-691	0
SAK2.5	0	284-691	0
SAK4	0	283-691	0
SAK6N	0	285-691	0
SAK10	0	280-998	0
SAK16	0	281-998	0
SAK35	0	264-120	14
Entrelec		264-220	8
MA2.5/5	0	264-132 (2)	3
M4/6	0	264-134 (4)	2
M6/8	0	262-132 (2)	3
M10/10	0	262-134 (4)	2
M16/12	0		
M35/16	0		

Cable Gland Entry Matrix

Entry Size	Side A-C	Side B-D
M16	2	0
M20	0	0
M25	0	0
M32	0	0
M40	0	0

Drilling Envelope Size

Side A-C	95 x 38mm
Side B-D	42 x 31mm

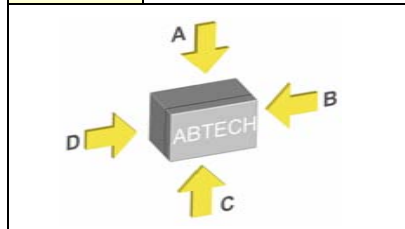

Example

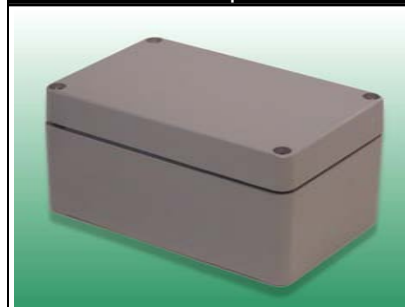

Technical

9

Others

8

ZP Range

7

Fire Rated

6

High Voltage

5

ZAG Range

4

BPGA Range

3

BPG Range

2

5X Range

1

ZAG 7 Drawing

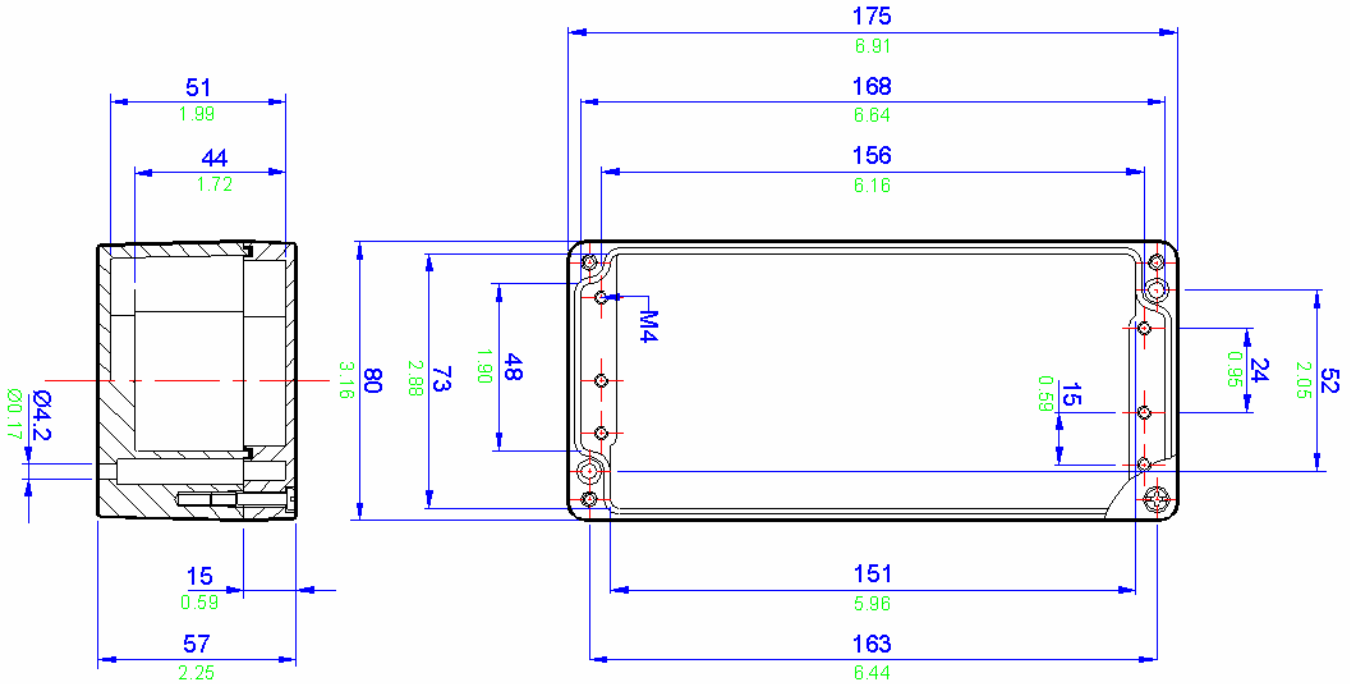

All blue dimensions in mm, all green dimensions in decimal inches (drawing not to scale)

ZAG 7 Specifications	
Width	175mm
Length	80mm
Depth	57mm
Material	Precision Cast AISi12 (LM24) aluminium alloy - unpainted
	Precision Cast AISi12 (LM24) aluminium alloy – painted epoxy polyester RAL7001 grey
Weight	540g
IP Rating	67
Temperature	-40° to 80° C (-40F to +176F) (standard neoprene gasket)
	-70° to 130° C (-94F to +266F) (silicone gasket)
Certification	ATEX EEx'e' BS EN 50019 (Zone 1 & 2)
	ATEX EEx'nA' BS EN 50021 (Zone 2)
	NEMA 4X (CSA, UL & FM (class 1 division 2)
Power Rating	2.900w

Terminal Populations			
Maximum Number of Rows			1
Weidmuller		Wago	
BK4 (4 way)	4	280-992	0
BK6 (6 way)	3	280-999	0
BK12 (12 way)	1	281-691	0
MK6/3	3	281-992	0
MK6/4	2	281-993	0
MK6/6	1	282-691	0
SAK2.5	0	284-691	0
SAK4	0	283-691	0
SAK6N	0	285-691	0
SAK10	0	280-998	0
SAK16	0	281-998	0
SAK35	0	264-120	23
Entrelec		264-220	13
MA2.5/5	0	264-132 (2)	4
M4/6	0	264-134 (4)	3
M6/8	0	262-132 (2)	4
M10/10	0	262-134 (4)	3
M16/12	0		
M35/16	0		

Cable Gland Entry Matrix		
Entry Size	Side A-C	Side B-D
M16	4	0
M20	0	0
M25	0	0
M32	0	0
M40	0	0

Drilling Envelope Size	
Side A-C	141 x 37mm
Side B-D	39 x 31mm

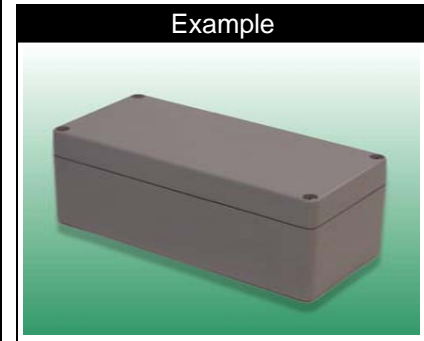
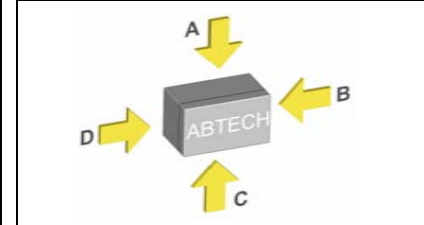

Technical 9	Others 8	ZP Range 7	Fire Rated 6	High Voltage 5	ZAG Range 4	BPGA Range 3	BPG Range 2	SX Range 1
----------------	-------------	---------------	-----------------	-------------------	------------------------	-----------------	----------------	---------------

ZAG 8 Drawing

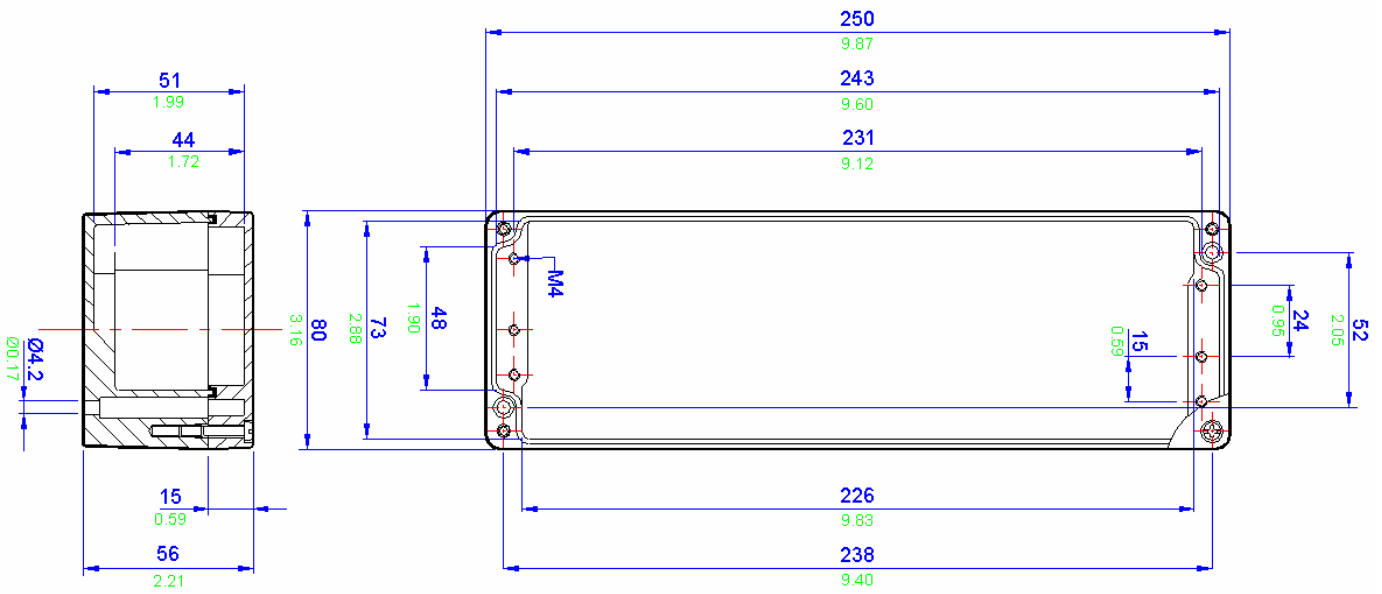

All blue dimensions in mm, all green dimensions in decimal inches (drawing not to scale)

ZAG 8 Specifications	
Width	250mm
Length	80mm
Depth	56mm
Material	Precision Cast AISi12 (LM24) aluminium alloy - unpainted
	Precision Cast AISi12 (LM24) aluminium alloy – painted epoxy polyester RAL7001 grey
Weight	710g
IP Rating	65
Temperature	-40° to 80° C (-40F to +176F) (standard neoprene gasket)
	-70° to 130° C (-94F to +266F) (silicone gasket)
Certification	ATEX EEx'e' BS EN 50019 (Zone 1 & 2)
	ATEX EEx'nA' BS EN 50021 (Zone 2)
	NEMA 4X (CSA, UL & FM (class 1 division 2)
Power Rating	2.900w

Terminal Populations			
Maximum Number of Rows			1
Weidmuller		Wago	
BK4 (4 way)	6	280-992	0
BK6 (6 way)	4	280-999	0
BK12 (12 way)	2	281-691	0
MK6/3	4	281-992	0
MK6/4	4	281-993	0
MK6/6	3	282-691	0
SAK2.5	0	284-691	0
SAK4	0	283-691	0
SAK6N	0	285-691	0
SAK10	0	280-998	0
SAK16	0	281-998	0
SAK35	0	264-120	35
Entrelec		264-220	21
MA2.5/5	0	264-132 (2)	7
M4/6	0	264-134 (4)	5
M6/8	0	262-132 (2)	7
M10/10	0	262-134 (4)	5
M16/12	0		
M35/16	0		

Cable Gland Entry Matrix		
Entry Size	Side A-C	Side B-D
M16	6	0
M20	0	0
M25	0	0
M32	0	0
M40	0	0

Drilling Envelope Size	
Side A-C	222 x 35mm
Side B-D	31 x 42mm

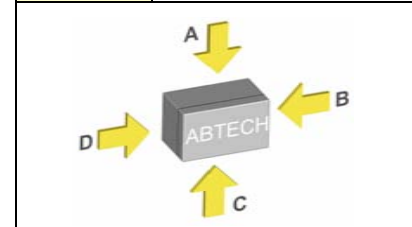

Example

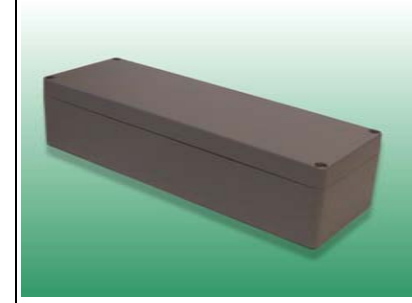

Technical 9	Others 8	ZP Range 7	Fire Rated 6	High Voltage 5	ZAG Range 4	BPGA Range 3	BPG Range 2	SX Range 1
----------------	-------------	---------------	-----------------	-------------------	----------------	-----------------	----------------	---------------

ZAG 9 and ZAG 9/9 Drawing

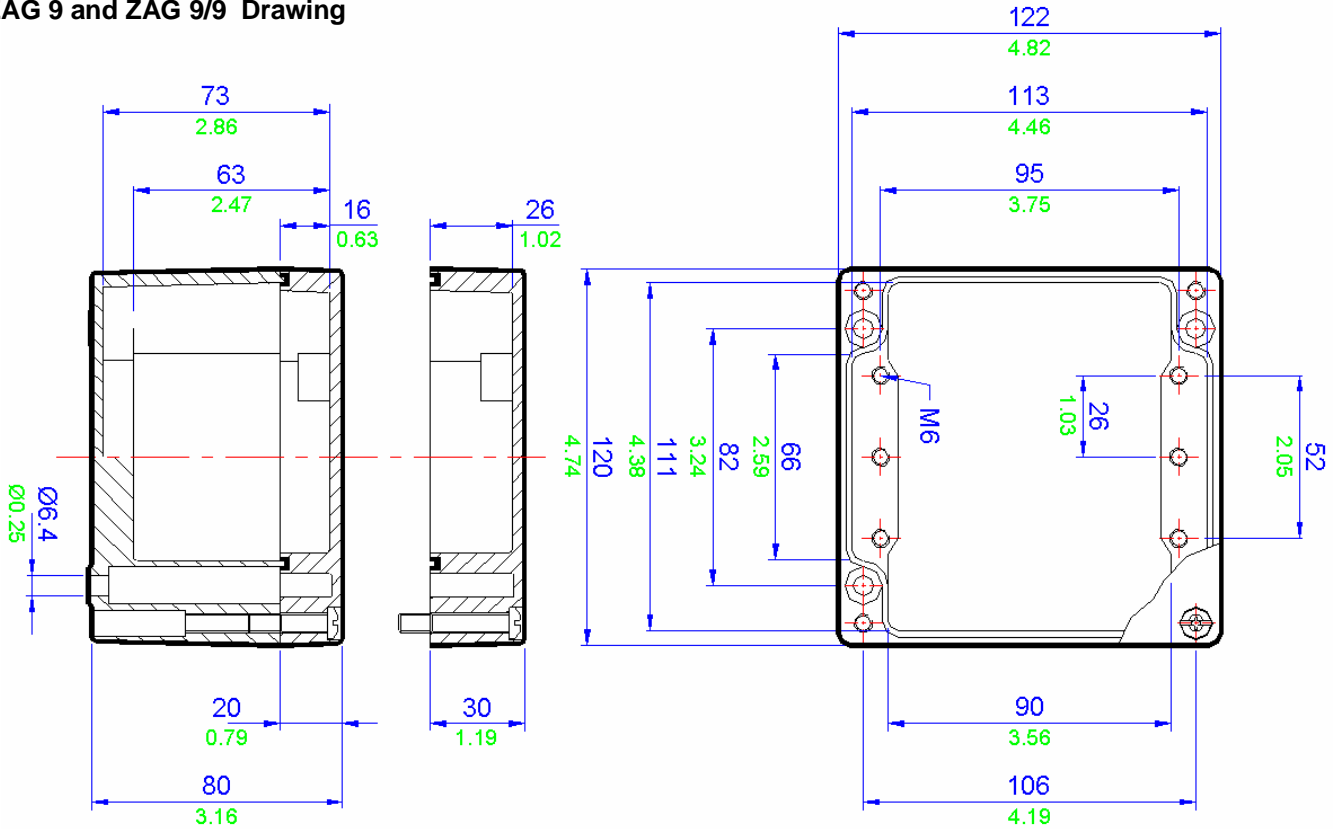

All blue dimensions in mm, all green dimensions in decimal inches (drawing not to scale)

ZAG 9 ZAG 9/9 Specifications	
Width	122mm
Length	120mm
Depth	80mm (ZAG 9) or 90mm (ZAG9/9)
Material	Precision Cast AISi12 (LM24) aluminium alloy - unpainted
	Precision Cast AISi12 (LM24) aluminium alloy – painted epoxy polyester RAL7001 grey
Weight	940g or 965g
IP Rating	67
Temperature	-40° to 80° C (-40°F to +176°F) (standard neoprene gasket)
	-70° to 130° C (-94°F to +266°F) (silicone gasket)
Certification	ATEX EEx'e' BS EN 50019 (Zone 1 & 2)
	ATEX EEx'nA' BS EN 50021 (Zone 2)
	NEMA 4X (CSA, UL & FM (class 1 division 2)
Power Rating	3.400w

Terminal Populations			
Maximum Number of Rows			1
Weidmuller		Wago	
BK4 (4 way)	2	280-992	15
BK6 (6 way)	2	280-999 *	15
BK12 (12 way)	1	281-691	13
MK6/3	1	281-992	13
MK6/4	1	281-993 *	13
MK6/6	1	282-691	10
SAK2.5	14	284-691 *	8
SAK4	13	283-691 *	6
SAK6N	10	285-691	0
SAK10 *	8	280-998	15
SAK16 *	7	281-998	13
SAK35 *	5	264-120	13
Entrelec		264-220	8
MA2.5/5	17	264-132 (2)	3
M4/6	14	264-134 (4)	2
M6/8	8	262-132 (2)	3
M10/10 *	8	262-134 (4)	2
M16/12 *	7		
M35/16 *	5		
* Care must be taken to ensure that the size of this enclosure can accommodate the cable bending radius.			

Cable Gland Entry Matrix		
Entry Size	Side A-C	Side B-D
M16	2	1
M20	2	1
M25	1	0
M32	0	0
M40	0	0

Drilling Envelope Size	
Side A-C	82 x 55mm
Side B-D	56 x 45mm

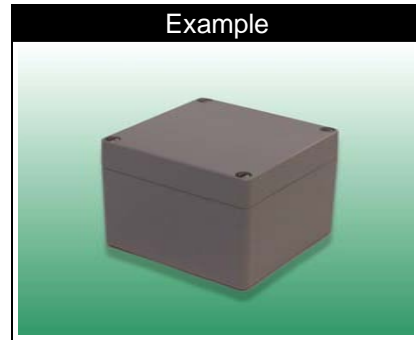
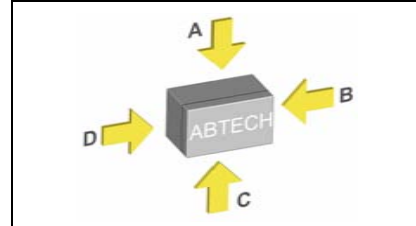

Technical 9	Others 8	ZP Range 7	Fire Rated 6	High Voltage 5	ZAG Range 4	BPGA Range 3	BPG Range 2	SX Range 1
----------------	-------------	---------------	-----------------	-------------------	----------------	-----------------	----------------	---------------

ZAG 10 and ZAG 10/9 Drawing

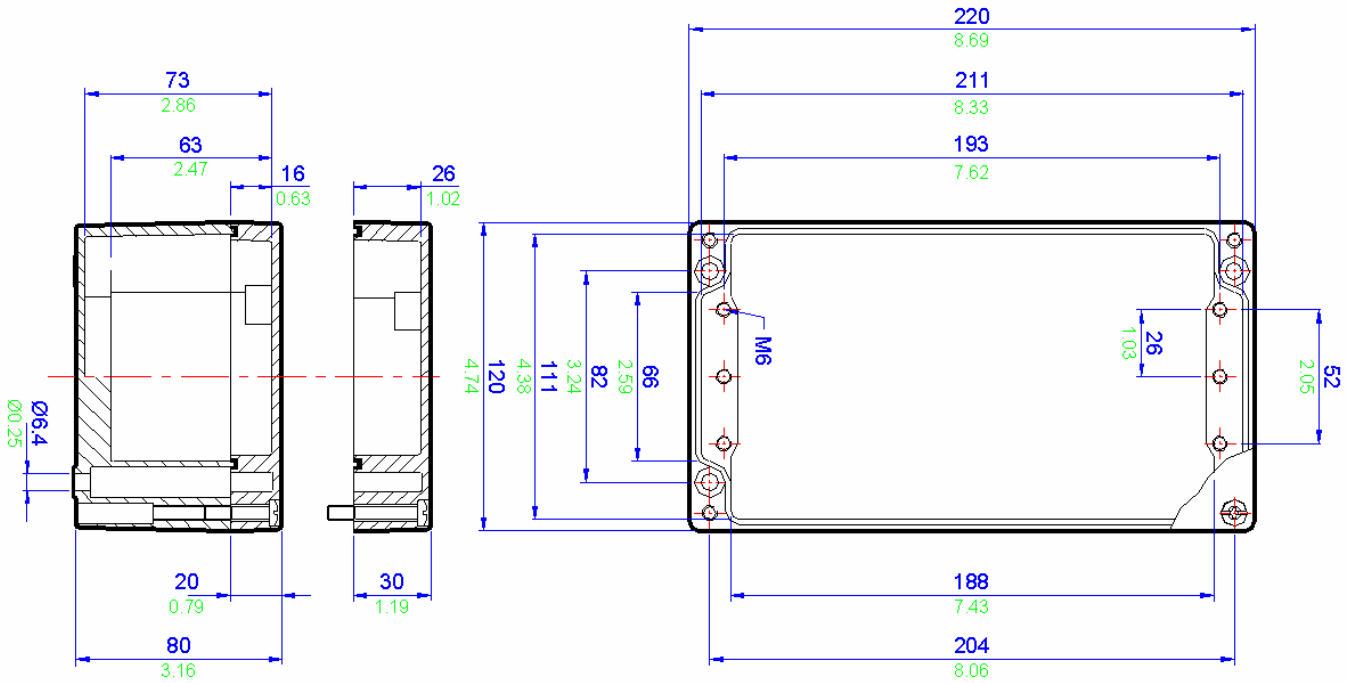

All blue dimensions in mm, all green dimensions in decimal inches (drawing not to scale)

ZAG 10 and ZAG 10/9 Specifications

Width	220mm
Length	120mm
Depth	80mm (ZAG 10) or 90mm (ZAG 10/9)
Material	Precision Cast AISi12 (LM24) aluminium alloy - unpainted
	Precision Cast AISi12 (LM24) aluminium alloy – painted epoxy polyester RAL7001 grey
Weight	1410g or 1440g
IP Rating	67
Temperature	-40° to 80° C (-40F to +176F) (standard neoprene gasket)
	-70° to 130° C (-94F to +266F) (silicone gasket)
Certification	ATEX EEx'e' BS EN 50019 (Zone 1 & 2)
	ATEX EEx'nA' BS EN 50021 (Zone 2)
	NEMA 4X (CSA, UL & FM (class 1 division 2)
Power Rating	5.400w

Terminal Populations

Maximum Number of Rows		1	
Weidmuller		Wago	
BK4 (4 way)	5	280-992	34
BK6 (6 way)	3	280-999	34
BK12 (12 way)	2	281-691	29
MK6/3	5	281-992	29
MK6/4	4	281-993 *	29
MK6/6	2	282-691	22
SAK2.5	30	284-691 *	18
SAK4	28	283-691 *	15
SAK6N	22	285-691	0
SAK10 *	18	280-998	34
SAK16 *	15	281-998	29
SAK35 *	11	264-120	30
Entrelec		264-220	18
MA2.5/5	36	264-132 (2)	6
M4/6	30	264-134 (4)	4
M6/8	22	262-132 (2)	6
M10/10 *	18	262-134 (4)	4
M16/12 *	15		
M35/16 *	11		

* Care must be taken to ensure that the size of this enclosure can accommodate the cable bending radius.

Cable Gland Entry Matrix

Entry Size	Side A-C	Side B-D
M16	6	1
M20	4	1
M25	3	1
M32	0	0
M40	0	0

Drilling Envelope Size

Side A-C	178 x 55mm
Side B-D	46 x 56mm

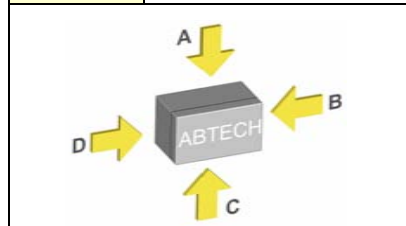

Example

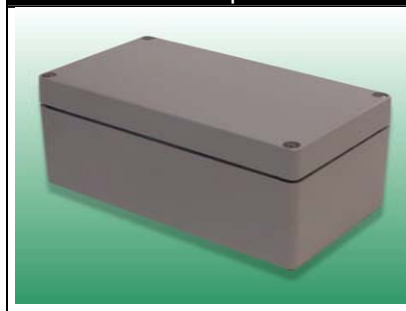

Technical

9

Others

8

ZP Range

7

Fire Rated

6

High Voltage

5

ZAG Range

4

BPGA Range

3

BPG Range

2

SX Range

1

ZAG 11 Drawing

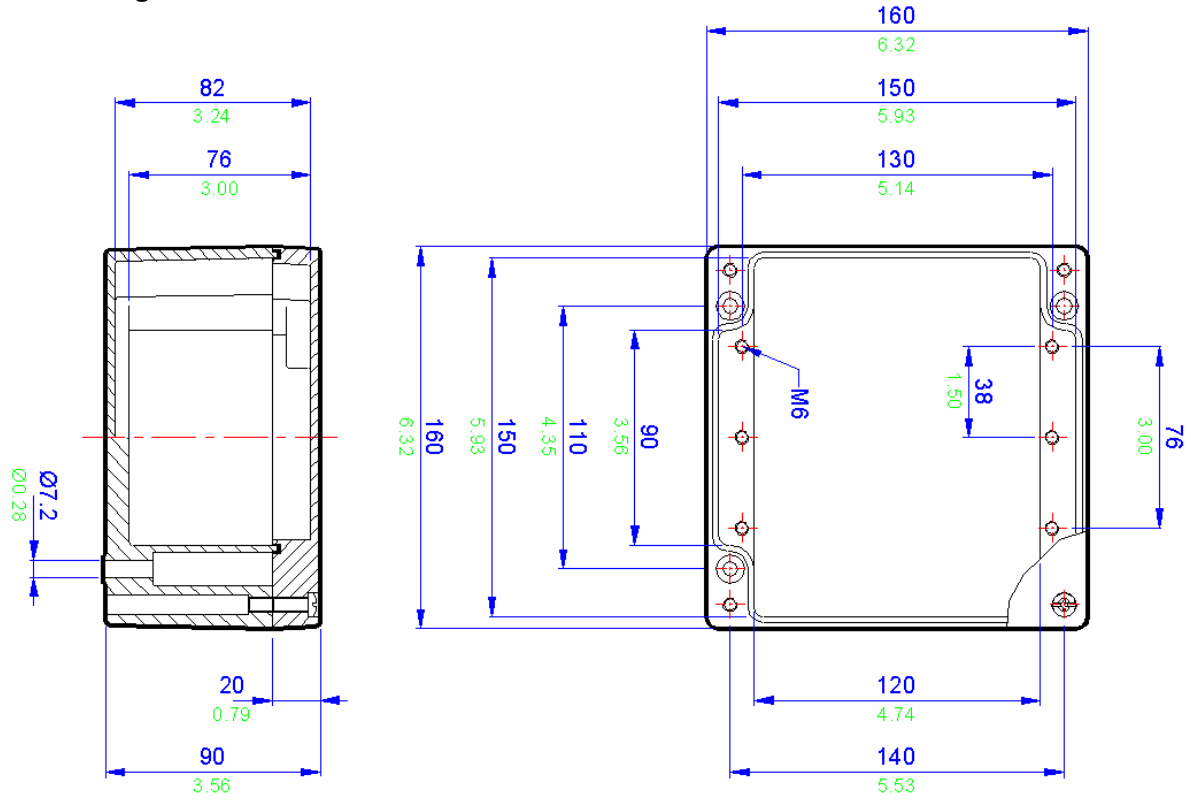

All blue dimensions in mm, all green dimensions in decimal inches (drawing not to scale)

ZAG 11 Specifications	
Width	160mm
Length	160mm
Depth	90mm
Material	Precision Cast AISI12 (LM24) aluminium alloy - unpainted
	Precision Cast AISI12 (LM24) aluminium alloy – painted epoxy polyester RAL7001 grey
Weight	1410g
IP Rating	67
Temperature	-40° to 80° C (-40°F to +176°F) (standard neoprene gasket)
	-70° to 130° C (-94°F to +266°F) (silicone gasket)
Certification	ATEX EEx'e' BS EN 50019 (Zone 1 & 2)
	ATEX EEx'nA' BS EN 50021 (Zone 2)
	NEMA 4X (CSA, UL & FM (class 1 division 2)
Power Rating	5.400w

Terminal Populations			
Maximum Number of Rows			1
Weidmuller		Wago	
BK4 (4 way)	3	280-992	22
BK6 (6 way)	2	280-999	22
BK12 (12 way)	1	281-691	19
MK6/3	3	281-992	19
MK6/4	2	281-993	19
MK6/6	1	282-691	15
SAK2.5	20	284-691 *	12
SAK4	19	283-691 *	10
SAK6N	15	285-691	0
SAK10 *	12	280-998	22
SAK16 *	10	281-998	19
SAK35 *	7	264-120	20
Entrelec		264-220	12
MA2.5/5	24	264-132 (2)	4
M4/6	20	264-134 (4)	3
M6/8	15	262-132 (2)	4
M10/10 *	12	262-134 (4)	2
M16/12 *	10		
M35/16 *	7		

* Care must be taken to ensure that the size of this enclosure can accommodate the cable bending radius.

Cable Gland Entry Matrix		
Entry Size	Side A-C	Side B-D
M16	6	2
M20	2	2
M25	2	1
M32	1	0
M40	0	0

Drilling Envelope Size	
Side A-C	110 x 65mm
Side B-D	80 x 56mm

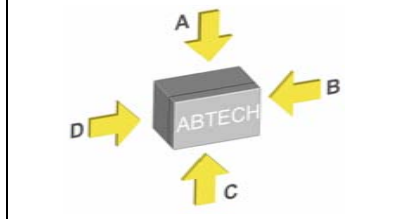

Example

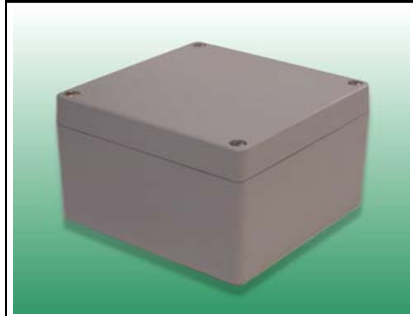

Technical 9	Others 8	ZP Range 7	Fire Rated 6	High Voltage 5	ZAG Range 4	BPGA Range 3	BPG Range 2	5X Range 1
----------------	-------------	---------------	-----------------	-------------------	----------------	-----------------	----------------	---------------

ZAG 12 Drawing

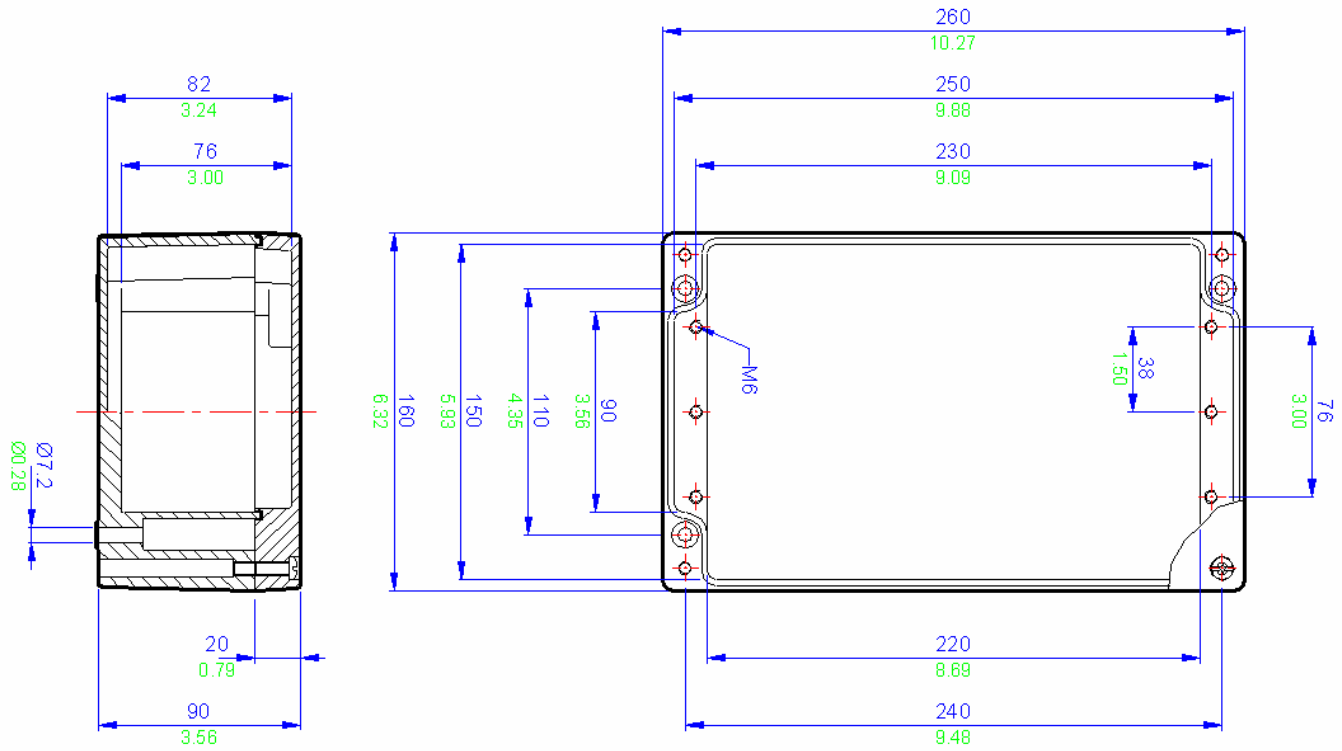

All blue dimensions in mm, all green dimensions in decimal inches (drawing not to scale)

ZAG 12 Specifications	
Width	260mm
Length	160mm
Depth	90mm
Material	Precision Cast AISi12 (LM24) aluminium alloy - unpainted
	Precision Cast AISi12 (LM24) aluminium alloy – painted epoxy polyester RAL7001 grey
Weight	1960g
IP Rating	67
Temperature	-40° to 80° C (-40°F to +176°F) (standard neoprene gasket)
	-70° to 130° C (-94°F to +266°F) (silicone gasket)
Certification	ATEX EEx'e' BS EN 50019 (Zone 1 & 2)
	ATEX EEx'n'A' BS EN 50021 (Zone 2)
	NEMA 4X (CSA, UL & FM (class 1 division 2)
Power Rating	8.000w

Terminal Populations			
Maximum Number of Rows			1
Weidmuller		Wago	
BK4 (4 way)	6	280-992	40
BK6 (6 way)	4	280-999	40
BK12 (12 way)	2	281-691	34
MK6/3	5	281-992	34
MK6/4	4	281-993	34
MK6/6	3	282-691	27
SAK2.5	36	284-691 *	21
SAK4	34	283-691 *	18
SAK6N	27	285-691	0
SAK10 *	22	280-998	40
SAK16 *	18	281-998	34
SAK35 *	14	264-120	36
Entelec		264-220	21
MA2.5/5	43	264-132 (2)	7
M4/6	36	264-134 (4)	5
M6/8	27	262-132 (2)	7
M10/10 *	22	262-134 (4)	5
M16/12 *	18		
M35/16 *	14		
* Care must be taken to ensure that the size of this enclosure can accommodate the cable bending radius.			

Cable Gland Entry Matrix		
Entry Size	Side A-C	Side B-D
M16	12	2
M20	6	2
M25	4	1
M32	3	0
M40	0	0

Drilling Envelope Size	
Side A-C	210 x 65mm
Side B-D	80 x 56mm

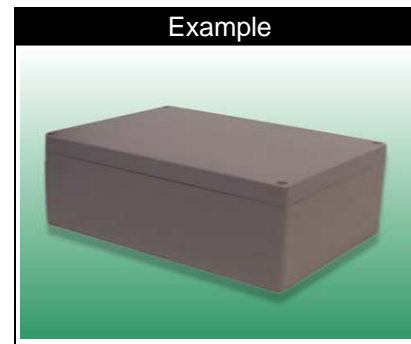
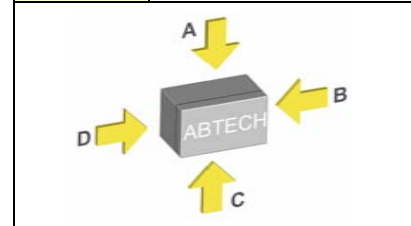

Technical 9	Others 8	ZP Range 7	Fire Rated 6	High Voltage 5	ZAG Range 4	BPGA Range 3	BPG Range 2	SX Range 1
----------------	-------------	---------------	-----------------	-------------------	----------------	-----------------	----------------	---------------

ZAG 13 Drawing

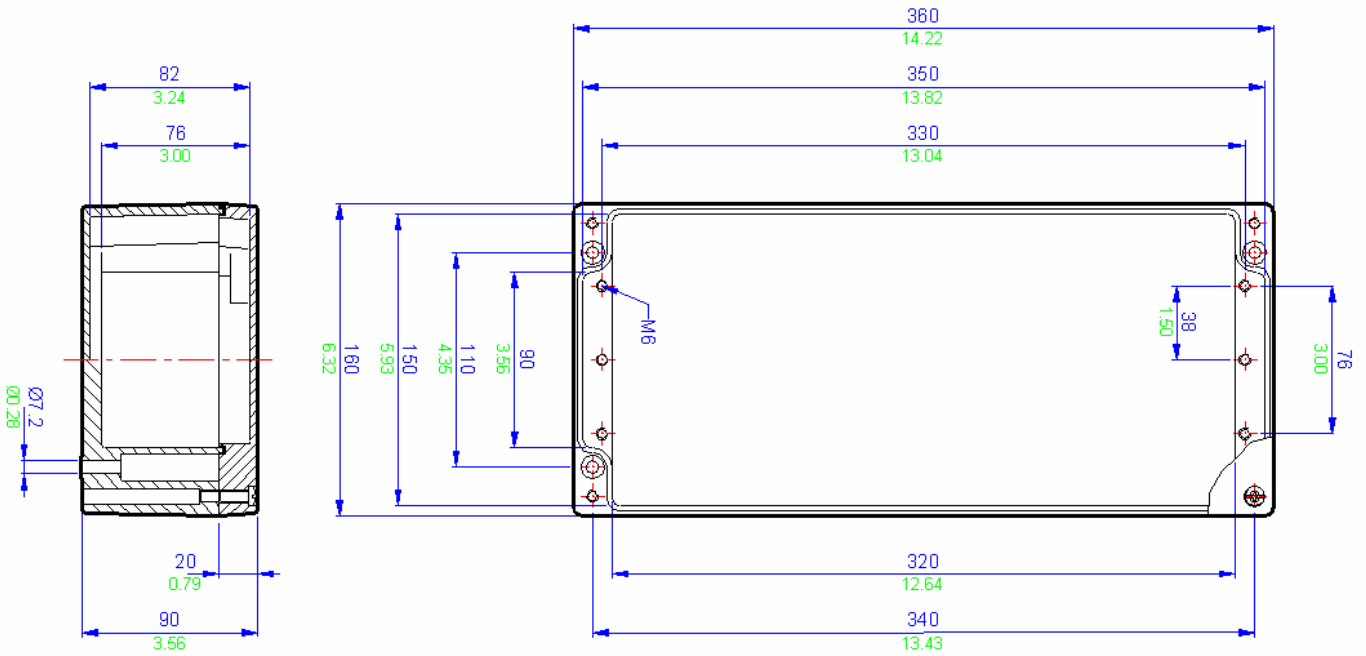

All blue dimensions in mm, all green dimensions in decimal inches (drawing not to scale)

ZAG 13 Specifications	
Width	360mm
Length	160mm
Depth	90mm
Material	Precision Cast AISi12 (LM24) aluminium alloy - unpainted
	Precision Cast AISi12 (LM24) aluminium alloy – painted epoxy polyester RAL7001 grey
Weight	2550g
IP Rating	65
Temperature	-40° to 80° C (-40°F to +176°F) (standard neoprene gasket)
	-70° to 130° C (-94°F to +266°F) (silicone gasket)
Certification	ATEX EE'x'e' BS EN 50019 (Zone 1 & 2)
	ATEX EE'x'nA' BS EN 50021 (Zone 2)
	NEMA 4X (CSA, UL & FM (class 1 division 2)
Power Rating	10.400w

Terminal Populations			
Maximum Number of Rows			1
Weidmuller		Wago	
BK4 (4 way)	9	280-992	58
BK6 (6 way)	6	280-999	58
BK12 (12 way)	3	281-691	50
MK6/3	7	281-992	50
MK6/4	6	281-993	50
MK6/6	4	282-691	39
SAK2.5	52	284-691 *	31
SAK4	48	283-691 *	26
SAK6N	40	285-691	0
SAK10 *	32	280-998	58
SAK16 *	26	281-998	50
SAK35 *	20	264-120	52
Entelec		264-220	31
MA2.5/5	63	264-132 (2)	11
M4/6	52	264-134 (4)	7
M6/8	40	262-132 (2)	10
M10/10 *	32	262-134 (4)	7
M16/12 *	26		
M35/16 *	20		
* Care must be taken to ensure that the size of this enclosure can accommodate the cable bending radius.			

Cable Gland Entry Matrix		
Entry Size	Side A-C	Side B-D
M16	18	2
M20	8	2
M25	6	1
M32	5	0
M40	0	0

Drilling Envelope Size	
Side A-C	314x 65mm
Side B-D	80 x 56mm

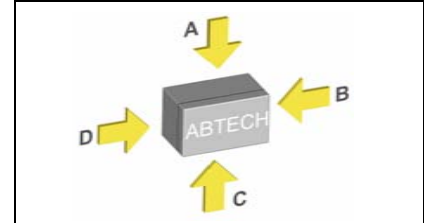

Example

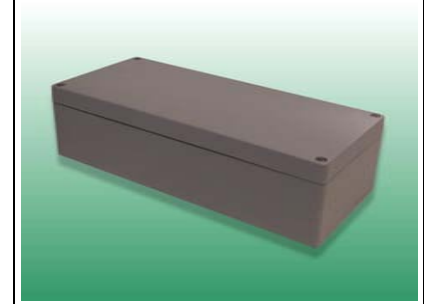

Technical 9	Others 8	ZP Range 7	Fire Rated 6	High Voltage 5	ZAG Range 4	BPGA Range 3	BPG Range 2	SX Range 1
----------------	-------------	---------------	-----------------	-------------------	----------------	-----------------	----------------	---------------

ZAG 14 Specifications

Width	560mm
Length	160mm
Depth	90mm
Material	Precision Cast AlSi12 (LM24) aluminium alloy - unpainted
	Precision Cast AlSi12 (LM24) aluminium alloy – painted epoxy polyester RAL7001 grey
Weight	4310g
IP Rating	65
Temperature	-40° to 80° C (-40°F to +176°F) (standard neoprene gasket)
	-70° to 130° C (-94°F to +266°F) (silicone gasket)
Certification	ATEX EEx'e' BS EN 50019 (Zone 1 & 2)
	ATEX EEx'nA' BS EN 50021 (Zone 2)
	NEMA 4X (CSA, UL & FM (class 1 division 2)
Power Rating	10.400w

Terminal Populations

Maximum Number of Rows		1	
Weidmuller		Wago	
BK4 (4 way)	14	280-992	96
BK6 (6 way)	10	280-999	96
BK12 (12 way)	5	281-691	82
MK6/3	12	281-992	82
MK6/4	11	281-993	82
MK6/6	7	282-691	63
SAK2.5	85	284-691 *	51
SAK4	78	283-691 *	42
SAK6N	64	285-691	0
SAK10 *	51	280-998	96
SAK16 *	43	281-998	82
SAK35 *	32	264-120	85
Entrelec		264-220	51
MA2.5/5	101	264-132 (2)	18
M4/6	85	264-134 (4)	12
M6/8	64	262-132 (2)	18
M10/10 *	51	262-134 (4)	12
M16/12 *	43		
M35/16 *	32		

* Care must be taken to ensure that the size of this enclosure can accommodate the cable bending radius.

Cable Gland Entry Matrix

Entry Size	Side A-C	Side B-D
M16	28	2
M20	12	2
M25	10	1
M32	8	0
M40	0	0

Drilling Envelope Size

Side A-C	240 x 65mm (x2)
Side B-D	56 x 80mm

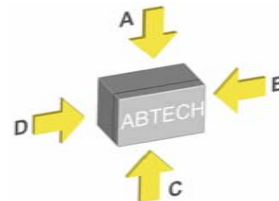

Example

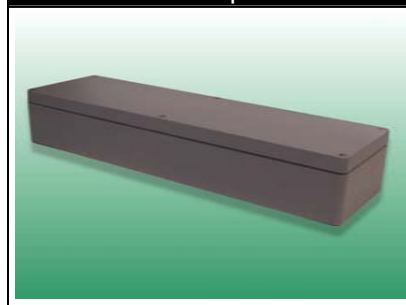

ZAG 15 Drawing

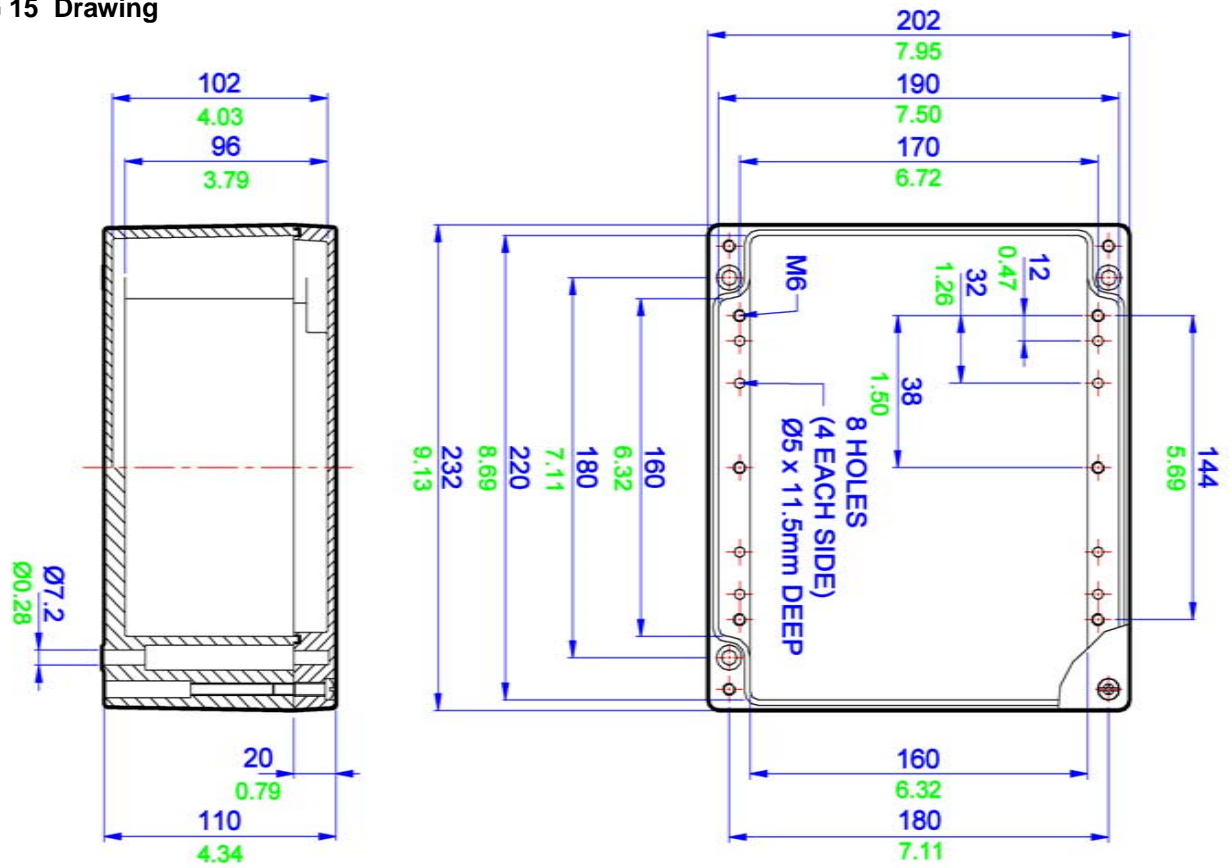

All blue dimensions in mm, all green dimensions in decimal inches (drawing not to scale)

ZAG 15 Specifications	
Width	202mm
Length	230mm
Depth	110mm
Material	Precision Cast AISI12 (LM24) aluminium alloy - unpainted
	Precision Cast AISI12 (LM24) aluminium alloy – painted epoxy polyester RAL7001 grey
Weight	2750g
IP Rating	65
Temperature	-40° to 80° C (-40°F to +176°F) (standard neoprene gasket)
	-70° to 130° C (-94°F to +266°F) (silicone gasket)
Certification	ATEX EEEx'e' BS EN 50019 (Zone 1 & 2)
	ATEX EEEx'nA' BS EN 50021 (Zone 2)
	NEMA 4X (CSA, UL & FM (class 1 division 2)
Power Rating	9.500w

Terminal Populations			
Maximum Number of Rows			2
Weidmuller		Wago	
BK4 (4 way)	10	280-992	70
BK6 (6 way)	8	280-999	70
BK12 (12 way)	4	281-691	60
MK6/3	10	281-992	60
MK6/4	8	281-993	60
MK6/6	4	282-691	46
SAK2.5	62	284-691 *	36
SAK4	58	283-691 *	15
SAK6N	48	285-691	10
SAK10 *	38	280-998	70
SAK16 *	32	281-998	60
SAK35 *	24	264-120	62
Entelec		264-220	36
MA2.5/5	76	264-132 (2)	12
M4/6	62	264-134 (4)	8
M6/8	48	262-132 (2)	12
M10/10 *	38	262-134 (4)	8
M16/12 *	32		
M35/16 *	24		

* Care must be taken to ensure that the size of this enclosure can accommodate the cable bending radius.

Cable Gland Entry Matrix		
Entry Size	Side A-C	Side B-D
M16	9	8
M20	6	6
M25	4	3
M32	2	2
M40	2	2

Drilling Envelope Size	
Side A-C	150 x 85mm
Side B-D	150 x 76mm

Example

ZAG 16 Drawing

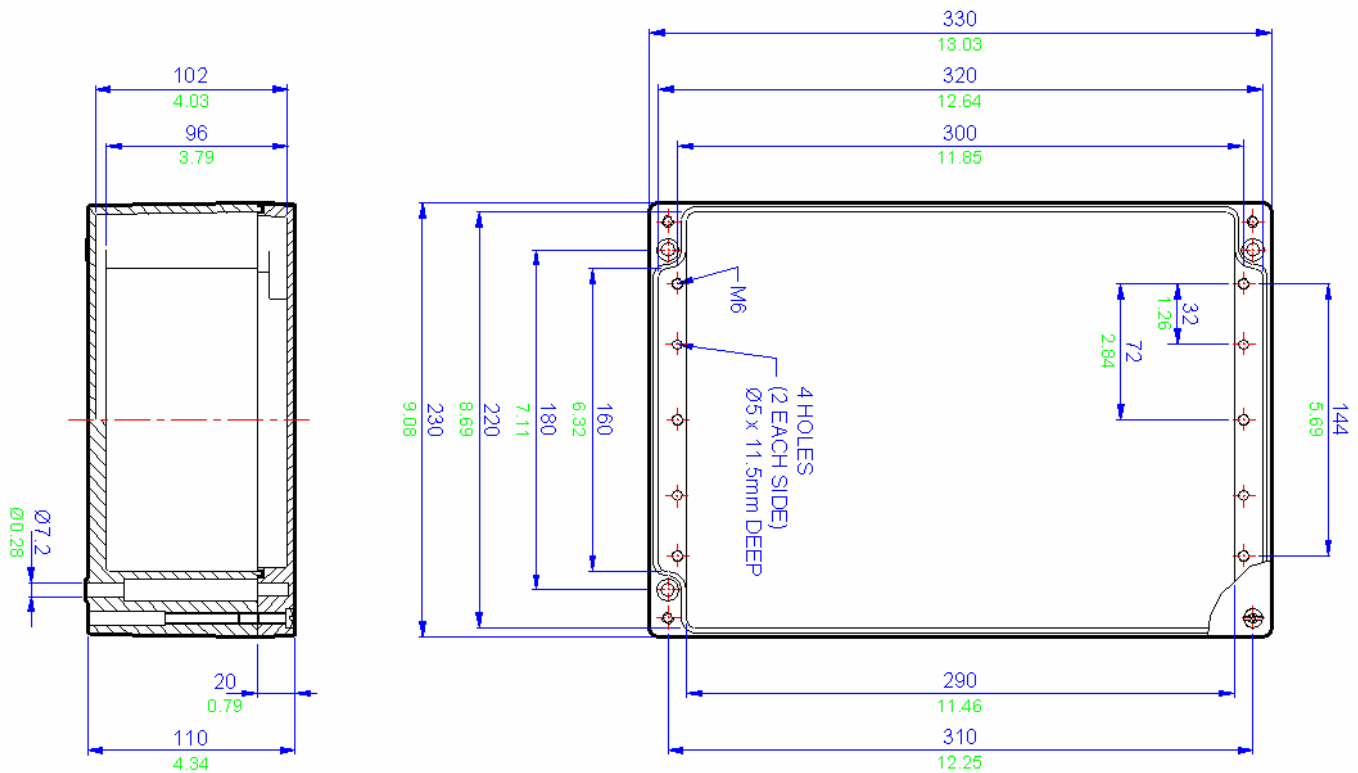

All blue dimensions in mm, all green dimensions in decimal inches (drawing not to scale)

ZAG 16 Specifications	
Width	330mm
Length	230mm
Depth	110mm
Material	Precision Cast AlSi12 (LM24) aluminium alloy - unpainted
	Precision Cast AlSi12 (LM24) aluminium alloy – painted epoxy polyester RAL7001 grey
Weight	4270g
IP Rating	66
Temperature	-40° to 80° C (-40°F to +176°F) (standard neoprene gasket)
	-70° to 130° C (-94°F to +266°F) (silicone gasket)
Certification	ATEX EEx'e' BS EN 50019 (Zone 1 & 2)
	ATEX EEx'hA' BS EN 50021 (Zone 2)
	NEMA 4X (CSA, UL & FM (class 1 division 2)
Power Rating	14.000w

Terminal Populations			
Maximum Number of Rows			2
Weidmuller		Wago	
BK4 (4 way)	16	280-992	108
BK6 (6 way)	12	280-999	108
BK12 (12 way)	6	281-691	92
MK6/3	14	281-992	92
MK6/4	12	281-993	92
MK6/6	8	282-691	72
SAK2.5	96	284-691 *	56
SAK4	88	283-691 *	24
SAK6N	72	285-691	16
SAK10 *	58	280-998	108
SAK16 *	48	281-998	92
SAK35 *	36	264-120	96
Entrelec		264-220	56
MA2.5/5	114	264-132 (2)	20
M4/6	96	264-134 (4)	14
M6/8	72	262-132 (2)	20
M10/10 *	58	262-134 (4)	12
M16/12 *	48		
M35/16 *	36		

* Care must be taken to ensure that the size of this enclosure can accommodate the cable bending radius.

Cable Gland Entry Matrix		
Entry Size	Side A-C	Side B-D
M16	21	8
M20	14	6
M25	10	3
M32	4	2
M40	4	2

Drilling Envelope Size	
Side A-C	284 x 85mm
Side B-D	150 x 76mm

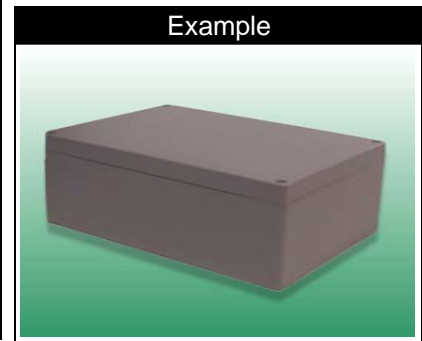
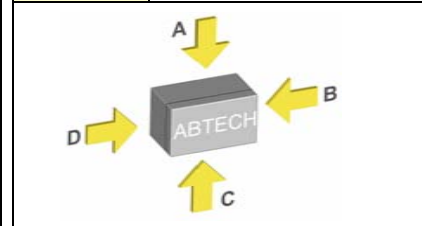

ZAG 21 Drawing

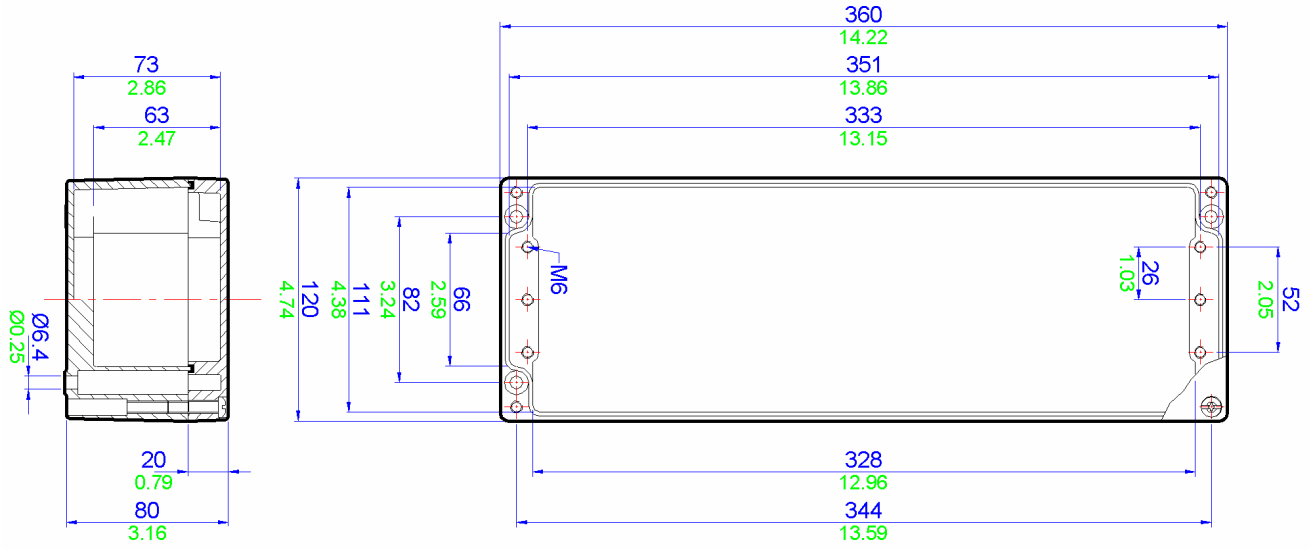

All blue dimensions in mm, all green dimensions in decimal inches (drawing not to scale)

ZAG 21 Specifications	
Width	120mm
Length	360mm
Depth	80mm
Material	Precision Cast AlSi12 (LM24) aluminium alloy - unpainted
	Precision Cast AlSi12 (LM24) aluminium alloy – painted epoxy polyester RAL7001 grey
Weight	2050g
IP Rating	66
Temperature	-40° to 80° C (-40°F to +176°F) (standard neoprene gasket)
	-70° to 130° C (-94°F to +266°F) (silicone gasket)
Certification	ATEX EEx'e' BS EN 50019 (Zone 1 & 2)
	ATEX EEx'nA' BS EN 50021 (Zone 2)
	NEMA 4X (CSA, UL & FM (class 1 division 2)
Power Rating	8.000w

Terminal Populations			
Maximum Number of Rows			1
Weidmuller		Wago	
BK4 (4 way)	9	280-992	58
BK6 (6 way)	6	280-999	58
BK12 (12 way)	3	281-691	50
MK6/3	6	281-992	50
MK6/4	6	281-993	50
MK6/6	4	282-691	39
SAK2.5	52	284-691 *	31
SAK4	48	283-691 *	26
SAK6N	40	285-691	0
SAK10 *	32	280-998	58
SAK16 *	26	281-998	50
SAK35	0	264-120	52
Entrelec		264-220	31
MA2.5/5	63	264-132 (2)	11
M4/6	52	264-134 (4)	7
M6/8	40	262-132 (2)	10
M10/10 *	32	262-134 (4)	7
M16/12 *	26		
M35/16	0		
* Care must be taken to ensure that the size of this enclosure can accommodate the cable bending radius.			

Cable Gland Entry Matrix		
Entry Size	Side A-C	Side B-D
M16	12	1
M20	8	1
M25	7	1
M32	0	0
M40	0	0

Drilling Envelope Size	
Side A-C	320 x 56mm
Side B-D	60 x 47mm

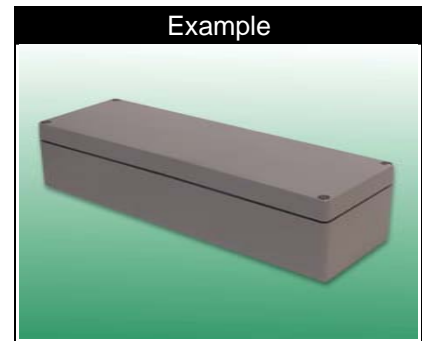
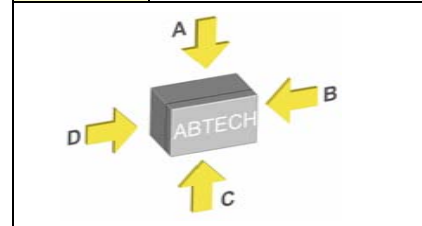

Technical 9	Others 8	ZP Range 7	Fire Rated 6	High Voltage 5	ZAG Range 4	BPGA Range 3	BPG Range 2	5X Range 1
----------------	-------------	---------------	-----------------	-------------------	----------------	-----------------	----------------	---------------

4
ZAG Range

